

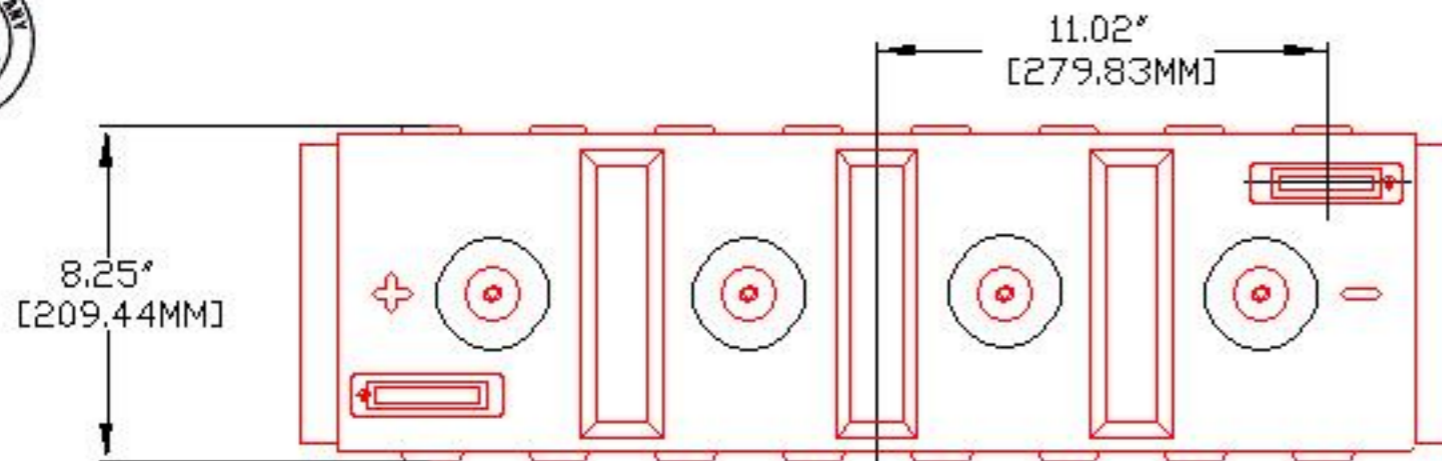

RailRoad

SERIES 5000

BATTERY TYPE	VOLTS	8	8 NS 23PR
DIMENSIONS			
LENGTH			718 MM 28 1/4 INCHES
WIDTH			210 MM 8 1/4 INCHES
HEIGHT			464 MM 18 1/4 INCHES
WEIGHT DRY			80 KG 176 LBS.
WEIGHT WET			110 KG 242 LBS.
CONTAINER CONSTRUCTION			
INNER CONTAINER			POLYPROPYLENE
INNER COVER			POLYPROPYLENE - HEAT SEALED TO INNER CONTAINER
OUTER CONTAINER			HIGH DENSITY POLYETHYLENE
OUTER COVER			HIGH DENSITY POLYETHYLENE SNAP FIT TO OUTER CONTAINER
HANDLES			MOLDED
PLATES PER CELL			23
ELECTROLYTE RESERVE	ABOVE PLATES		143 MM 5.63 INCHES
DESIGN CRITREA	3 YEAR WARRANTY		12 YEAR LIFE
POSITIVE PLATE DIMENSION			
HEIGHT			222 MM 8.750 INCHES
WIDTH			143 MM 5.625 INCHES
THICKNESS			3.81 MM 0.150 INCHES
NEGATIVE PLATE DIMENSION			
HEIGHT			222 MM 8.750 INCHES
WIDTH			143 MM 5.625 INCHES
THICKNESS			3.05 MM 0.120 INCHES
SEPARATOR INSULATION	SEPARATOR THICKNESS		0.105 INCH
	0.020" GLASS MAT		
TERMINALS	FLAG WITH STAINLESS STEEL NUTS AND BOLTS		
COLD CRANK	CCA	0°F / -17.8°C	1520
	MCA	32°F / 0°C	1900
			RESERVE MINUTES AT 25A
			716
CAPACITY	20 HR RATE		430
			CAP / AH CURRENT / AMPS
CAPACITY AT THE 20 HOUR RATE	1.265 SP. GR.		430 21.5
CAPACITY AT THE 15 HOUR RATE	1.265 SP. GR.		409 27.2
CAPACITY AT THE 12 HOUR RATE	1.265 SP. GR.		387 32.3
CAPACITY AT THE 10 HOUR RATE	1.265 SP. GR.		370 37.0
CAPACITY AT THE 8 HOUR RATE	1.265 SP. GR.		352 44.0
CAPACITY AT THE 6 HOUR RATE	1.265 SP. GR.		323 53.8
CAPACITY AT THE 5 HOUR RATE	1.265 SP. GR.		305 61
CAPACITY AT THE 4 HOUR RATE	1.265 SP. GR.		284 71
CAPACITY AT THE 3 HOUR RATE	1.265 SP. GR.		258 86
CAPACITY AT THE 2 HOUR RATE	1.265 SP. GR.		224 112
CAPACITY AT THE 1 HOUR RATE	1.265 SP. GR.		155 155



PART NUMBER 8-NS-23P

WEIGHT WET: 242 LB / 110 KG

WEIGHT DRY: 176 LB / 80 KG

CCA @ 0°F / -17.8 °C 1,520 A

CCA @ 32°F / 0 °C 1,900 A

VOLTAGE: 8 V

OVERALL DIMENSIONS: 28 1/4" X 8 1/4" X 18 1/4"



MAX HEIGHT WITH OPTIONAL HYDROCAPS 18.63" / 473 MM

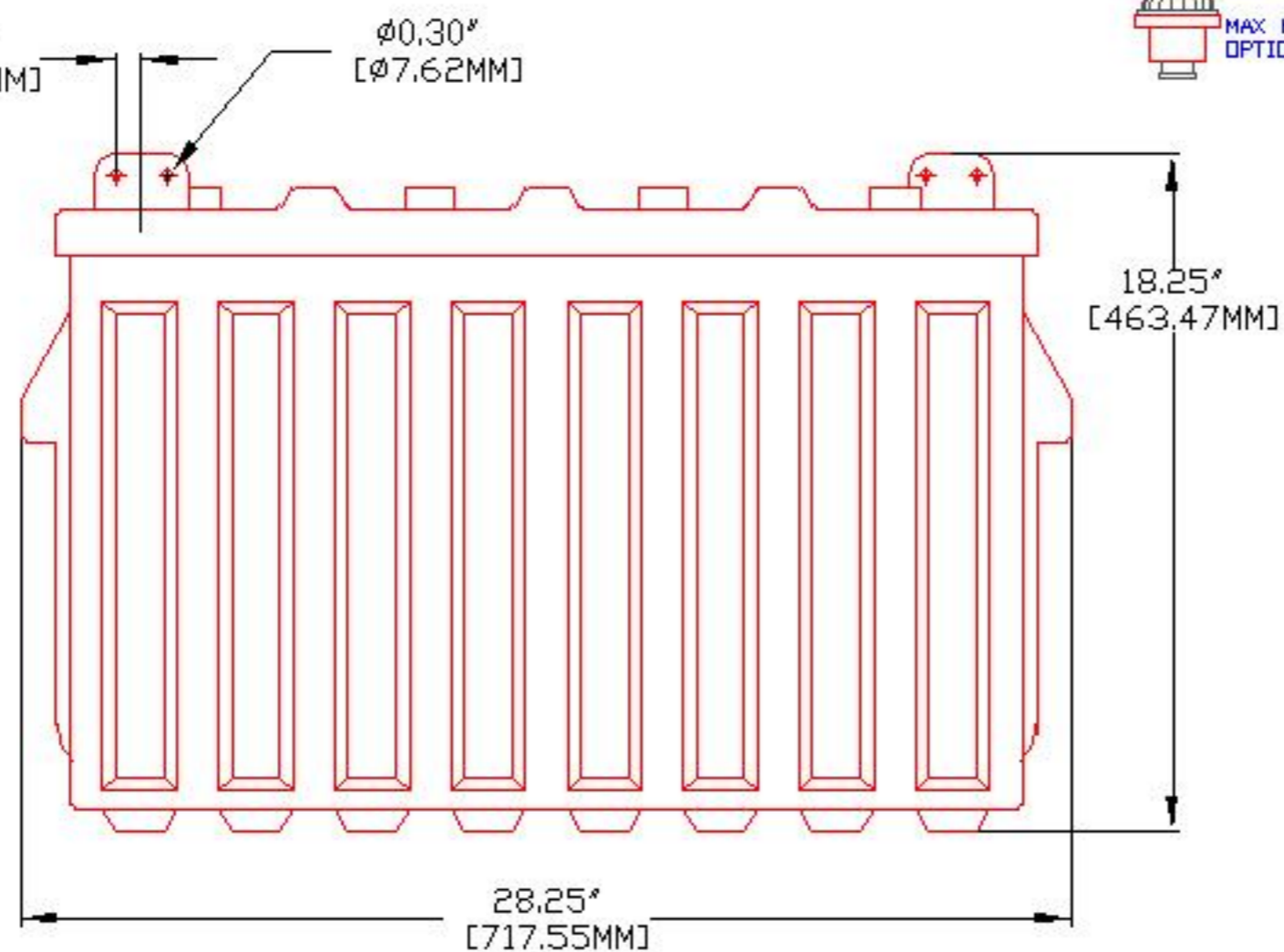
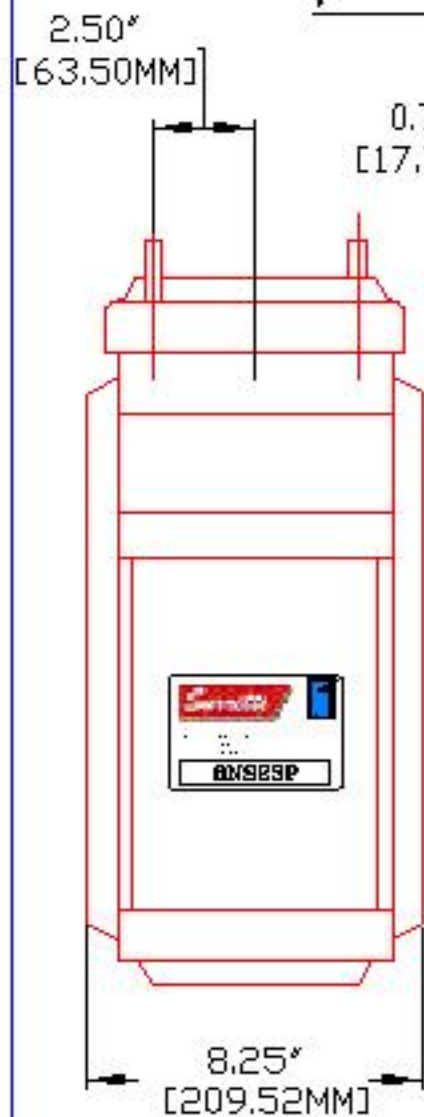

Surrette	
BATTERY COMPANY LIMITED SPRINGHILL / NOVA SCOTIA / CANADA PRODUCT OF CANADA	
TITLE:	8NS23P
DESCRIPTION:	8V 500/5000 SERIES
CONTACT INFO:	WEB: WWW.SURRETTE.COM E-MAIL: SALES@SURRETTE.COM PHONE: 1-800-681-9914
SCALE:	1" = 6" 1" = 4" JPEG 8.5" X 11" 11" X 17" NOT TO SCALE
Drawn by:	Approved By:
S. WILES	D. SURRETTE
DATE:	REVISION:
16-Feb-01	2.1
DRAWING NO.:	DWG 013, 8NS23P