

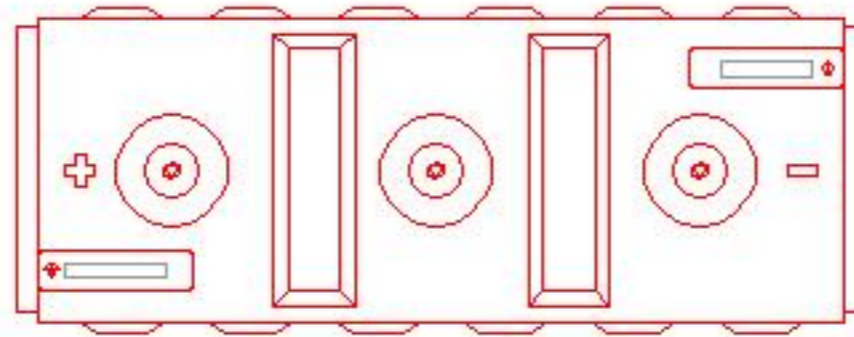



DEEP CYCLE-CAR LIGHTING

SERIES 4000

BATTERY TYPE	VOLTS	6	6 HHG 31PR
DIMENSIONS			
LENGTH	527 MM	20 3/4	INCHES
WIDTH	203 MM	8	INCHES
HEIGHT	302 MM	11 7/8	INCHES
WEIGHT DRY	44 KG	96	LBS.
WEIGHT WET	57 KG	125	LBS.
CONTAINER CONSTRUCTION			
INNER CONTAINER	POLYPROPYLENE		
INNER COVER	POLYPROPYLENE - HEAT SEALED TO INNER CONTAINER		
OUTER CONTAINER	HIGH DENSITY POLYETHYLENE		
OUTER COVER	HIGH DENSITY POLYETHYLENE SNAP FIT TO OUTER CONTAINER		
HANDLES	MOLDED		
PLATES PER CELL	31		
ELECTROLYTE RESERVE	ABOVE PLATES	70 MM	2.75 INCHES
DESIGN CRITREA	2 YEAR WARRANTY	1300 CYCLES	8 YEAR LIFE
POSITIVE PLATE DIMENSION			
HEIGHT	140 MM	5.500	INCHES
WIDTH	143 MM	5.625	INCHES
THICKNESS	3.81 MM	0.150	INCHES
NEGATIVE PLATE DIMENSION			
HEIGHT	140 MM	5.500	INCHES
WIDTH	137 MM	5.375	INCHES
THICKNESS	2.49 MM	0.098	INCHES
SEPARATOR	SEPARATOR THICKNESS	0.081 INCH	
INSULATION	0.020" GLASS MAT		
TERMINALS	FLAG WITH STAINLESS STEEL NUTS AND BOLTS		
COLD CRANK	CCA	0°F / -17.8°C	1444
	MCA	32°F / 0°C	1805
	RESERVE	696	
	MINUTES AT 25A		
CAPACITY	20 HR RATE	344	
		CAP / AH	CURRENT / AMPS
CAPACITY AT THE 20 HOUR RATE	1.265 SP. GR.	344	17.2
CAPACITY AT THE 15 HOUR RATE	1.265 SP. GR.	327	21.8
CAPACITY AT THE 12 HOUR RATE	1.265 SP. GR.	310	25.8
CAPACITY AT THE 10 HOUR RATE	1.265 SP. GR.	296	29.6
CAPACITY AT THE 8 HOUR RATE	1.265 SP. GR.	282	35.3
CAPACITY AT THE 6 HOUR RATE	1.265 SP. GR.	258	43.0
CAPACITY AT THE 5 HOUR RATE	1.265 SP. GR.	244	49
CAPACITY AT THE 4 HOUR RATE	1.265 SP. GR.	227	57
CAPACITY AT THE 3 HOUR RATE	1.265 SP. GR.	206	69
CAPACITY AT THE 2 HOUR RATE	1.265 SP. GR.	179	89
CAPACITY AT THE 1 HOUR RATE	1.265 SP. GR.	124	124



PART NUMBER:	6-HHG-31P
WEIGHT WET:	125 LB / 57 KG
WEIGHT DRY:	96 LB / 44 KG
CAPACITY:	344 AH 20 HR
CCA @ 0°F / -17.8 °C:	1,445 A
CCA @ 32°F / 0 °C:	1,806 A
VOLTAGE:	6 V
OVERALL DIMENSIONS:	20 3/4" x 8" x 11 7/8"
 MAX HEIGHT WITH OPTIONAL HYDROCAPS:	12.43" / 316 MM

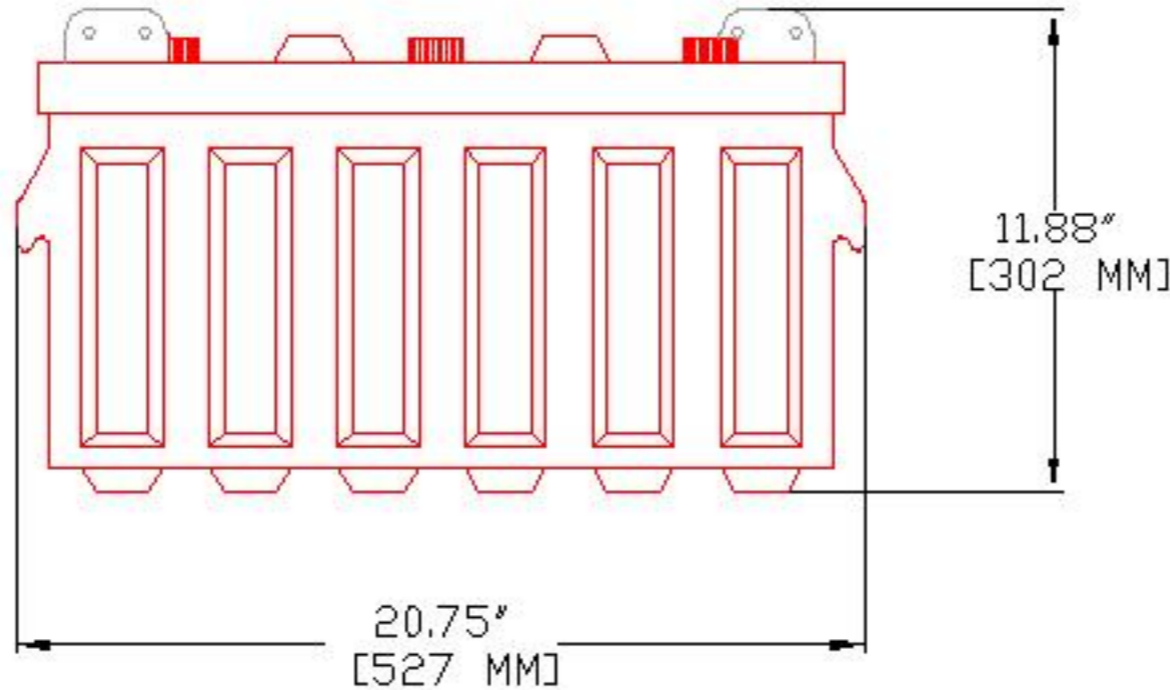

Surrette	
BATTERY COMPANY LIMITED SPRINGHILL / NOVA SCOTIA / CANADA PRODUCT OF CANADA	
TITLE: 6HHG31P	
DESCRIPTION: 6V DEEP CYCLE 400/4000 SERIES	
CONTACT INFO: WEB: WWW.SURRETTE.COM E-MAIL: SALES@SURRETTE.COM PHONE: 1-800-681-9914	
SCALE: 1" = 6" 1" = 4" JPEG 8.5" X 11" 11" X 17" NOT TO SCALE	
Drawn by: S. WILES	Approved By: D. SURRETTE
DATE: 20-Feb-01	REVISION 1.1
DRAWING NO.: DWG 032, BD6HHG31P	